

Precautions for use of Compact Chip LED products

- (1) When adopting the product for mass production, please exchange formal specifications with us.
- (2) Do not reverse-engineer the product including disassemble or analyze without our approval.
- (3) The product is not in conformity to IATF16949 or intended to be used for in-vehicle application. The product is not designed or manufactured to be used for special application (e.g. trains, ships, airplanes, spaceships, submarine repeaters, atomic energy control systems, traffic equipment, combustion equipment, medical devices, and safety devices). We will not guarantee any application suitability for goods like those described above that require special quality and reliability. In cases where the product is used in special applications and it causes extensive property damage, threatens human life or damages the human body, we will not be held liable.
- (4) The specification and appearance of the product may change without notice for improvement, etc.
- (5) This technical information and data is provided for users as is, and we do not guarantee that it is free from errors or defect in technical information and data, or this technical information and data conform to special applications, or this technical information and data does not infringe any rights of the user or third parties other than the user, or any other contents (including changes in contents for improvement of the specification and appearance of the product) thereof.

CL-503 Series



1.5(L) ×
1.3(W) × 0.35(H)mm

特征 Features

1. 同一封装内3色发光
3 colors emitting from a single package
2. 正面发光, 超小型·薄型
Upward-lighting, ultra-compact/thin type

●绝对最大额定值 Absolute Maximum Rating (Ta 25°C)

产品代码 Product code	Color variation	P*1 (mW)	Pd (mW)	If (mA)	IFP (mA)	VR (V)	Top (°C)	Tst (°C)
CL-503S-TCC	红色 Red	125	78	30	100*2	4	-25~+80	-30~+85
	绿色 Green		80	20				
	蓝色 Blue		73	20				

(Ta 25°C)

产品代码 Product code	Color variation	P*1 (mW)	Pd (mW)	If (mA)	IFP (mA)	VR (V)	Top (°C)	Tst (°C)
CL-503T	红色 Red	125	78	30	100*2	4	-25~+80	-30~+85
	绿色 Green		76	20				
	蓝色 Blue		72	20				

* 1 P表示同时亮灯时的全部的容许损耗。 / * 2 IFP的条件为duty 1/10, 脉冲宽度为0.1msec。
* 1 P means total value of power dissipation when both colors are on. / * 2 Conditions for IFP are pulse of 1/10 duty and 0.1msec width.

●电气·光学特性 Electrical and Optical Characteristics

[CL-503S-TCC] (Ta 25°C)

参数 Parameter	Color variation	Symbol	Conditions	MIN	TYP	MAX	Unit
正向电压 Forward Voltage	红色 Red	VF	IF=5mA	—	1.85	2.47	V
	绿色 Green			—	2.70	3.19	
	蓝色 Blue			—	2.75	3.19	
反向电流 Reverse Current	红色 Red	IR	VR=4V	—	—	100	μA
	绿色 Green			—	—	2	
	蓝色 Blue			—	—	2	
光强 Luminous Intensity*	红色 Red	Iv	IF=5mA	17	33	—	mcd
	绿色 Green			82	220	—	
	蓝色 Blue			18	65	—	
主波长 Dominant Wavelength	红色 Red	λd	IF=5mA	—	618	—	nm
	绿色 Green			—	530	—	
	蓝色 Blue			—	470	—	

[CL-503T] (Ta 25°C)

参数 Parameter	Color variation	Symbol	Conditions	MIN	TYP	MAX	Unit
正向电压 Forward Voltage	红色 Red	VF	IF=5mA	1.36	1.85	2.47	V
	绿色 Green			2.33	2.70	3.19	
	蓝色 Blue			2.33	2.75	3.19	
反向电流 Reverse Current	红色 Red	IR	VR=4V	—	—	100	μA
	绿色 Green			—	—	2	
	蓝色 Blue			—	—	2	
光强 Luminous Intensity*	红色 Red	Iv	IF=5mA	16	36	79	mcd
	绿色 Green			55	180	330	
	蓝色 Blue			11	40	88	
主波长 Dominant Wavelength	红色 Red	λd	IF=5mA	603	618	642	nm
	绿色 Green			518	530	542	
	蓝色 Blue			461	470	477	

* 符合NIST标准 * Compliant with NIST standards

●外形尺寸图 Outline drawing

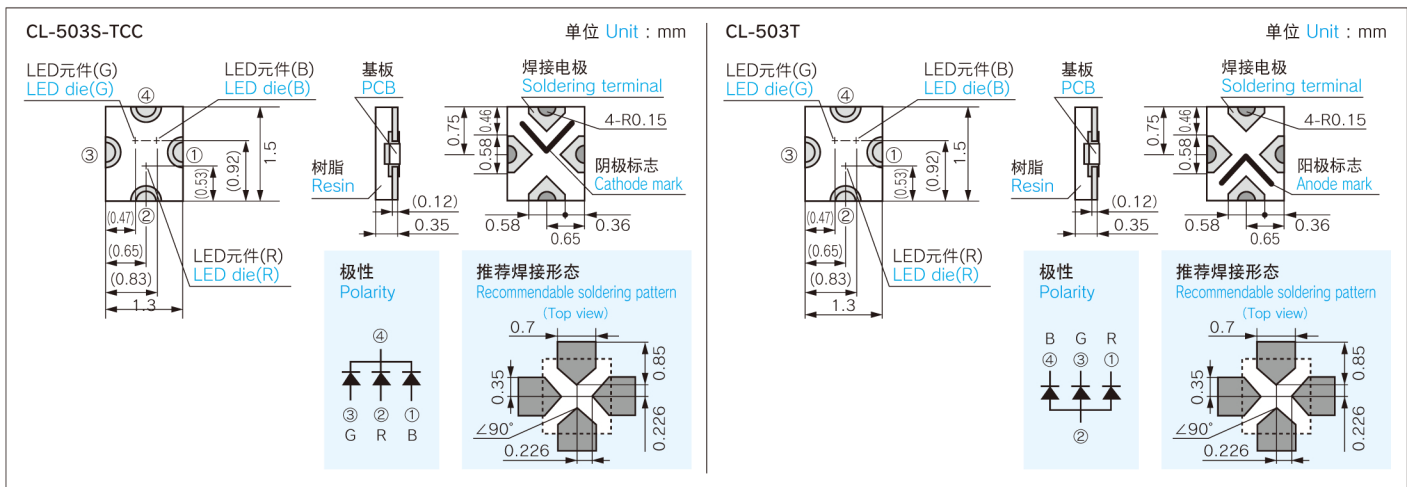

包装数量 : 5,000个/卷 (φ 180mm) Loaded quantity: 5,000pcs./1 reel (φ 180mm)